

Thermal Bypass Assembly

This thermal bypass valve is ideally suited for hydrostatic drive circuits which require fast warm-up, controlled fluid temperature, and low return line back pressure. When installed in the return line of a hydraulic circuit that employs an oil cooler, this device will modulate fluid temperature by either shifting

return line flow through the cooler, or bypassing directly to the reservoir. In addition, a built-in pressure relief function automatically relieves excess pressure to the reservoir should the cooler become restricted and resultant pressure drop become too high for the cooler circuit.

Features

1. Operating Characteristics

- A. Mode #1: At temperatures below the shift temperature oil flows from inlet to tank port.
- B. Mode #2: At temperatures between the start of shift and full shift the flow from the inlet port is divided between the cooler and tank ports.
- C. Mode #3: At temperatures above the full shift temperature inlet flow is through the cooler port.
- D. Mode #4: At temperatures above the full shift temperature the excess pressure is relieved through the tank port.

2. Standard Shift Temperatures

100°F (38°C) 120°F (49°C) 140°F (60°C) 160°F (71°C)

3. Full Shift (Cooler Port Open) Temperatures

Shift temperature plus 25°F (14°C)

4. Relief Valve Setting

65 psi (4.5 bar)
Consult factory for other pressure settings.

5. Maximum Operating Pressure

250 psi (17 bar)

6. Proof Pressure

300 psi (21 bar)

7. Minimum Burst Pressure

- A. Up to the full shift temperature: 325 psi (22 bar).
- B. Above the full shift temperature: 600 psi (41 bar).

8. Minimum Operating Temperature

-30°F (-34°C)

9. Maximum Operating Temperature

Shift temperature plus 75°F (24°C)

10. Maximum Flow Rating

60 gpm (227 l/m)

11. Leakage @ 250 psi (17 bar) and 60 gpm (227 l/m) Inlet Flow

- A. Cooler Port:
 - 1. 0.5 gpm (2 l/m) maximum up to 5°F (3°C) before shift temp.
 - 2. 1.0 gpm (4 l/m) maximum from 5°F (3°C) before shift to shift.
- B. Tank Port: 0.10 gpm (0.4 l/m) maximum

12. Operating Fluid

Mineral base hydraulic fluids

13. Construction

Aluminum die-cast housing

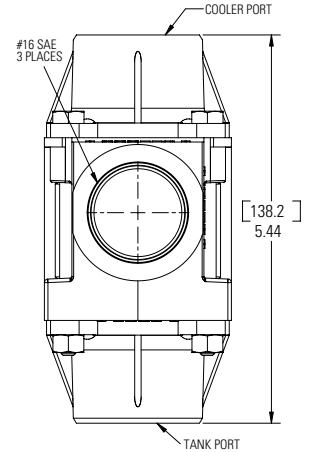

Graphic Symbol

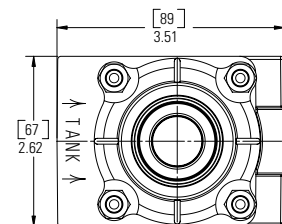
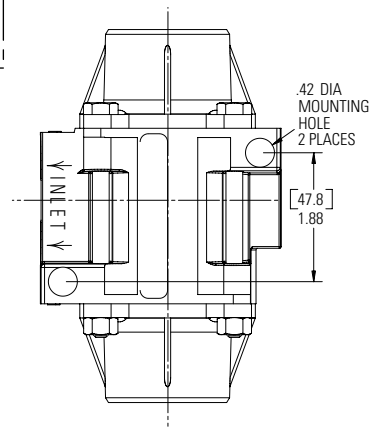
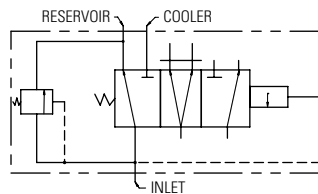

For 120° F Shift Temperature

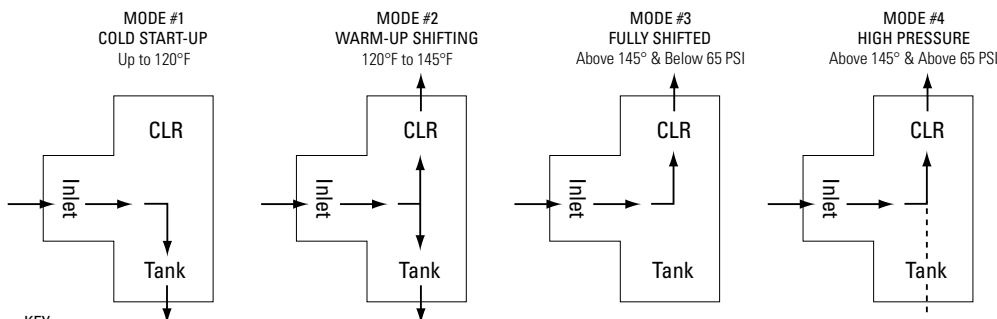

KEY
 → Oil Flow
 - - - Excess pressurized oil

NOTE: If the temperature drops below 145°F the valve will shift back to modes 2 or 1.

Thermal Bypass Assembly

Pressure Drop (Mobile DTE 26 OIL)

Inlet Port Thru Tank Port
@ 100°F (38°C) (300 SUS)

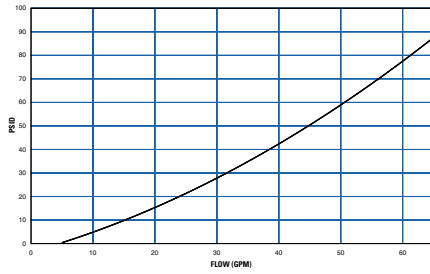

Inlet Port Thru Cooler Port
@ 145°F (63°C) (110 SUS)

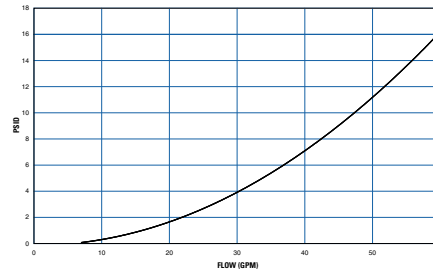

Inlet Port Over Integral Relief Valve
@ 170°F (77°C) (78 SUS)

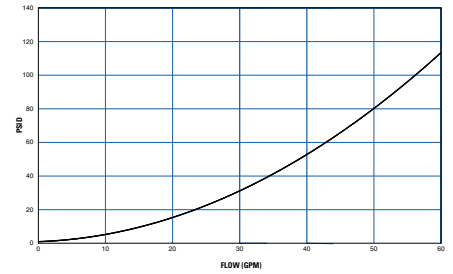

NOTE: Pressure drop shown is added to relief valve crack pressure for total pressure drop.

PART NUMBER	SHIFT TEMPERATURE
65654	100°F (38°C)
65655	120°F (49°C)
65656	140°F (60°C)
65657	160°F (71°C)

--	--	--	--	--

Part Number

--	--

Pressure Setting
65 = Standard, 65 PSI
Optional pressure settings
available in 5 PSI increments,
up to 85 PSI.

Thermal Bypass Assembly